

THIS DRAWING CONTAINS INFORMATION WHICH IS THE PROPRIETARY PROPERTY OF QUATROSENSE ENVIRONMENTAL LTD. THIS DRAWING IS RECEIVED IN CONFIDENCE AND ITS CONTENTS MAY NOT BE DISCLOSED WITHOUT THE PRIOR WRITTEN CONSENT OF QUATROSENSE ENVIRONMENTAL LTD.

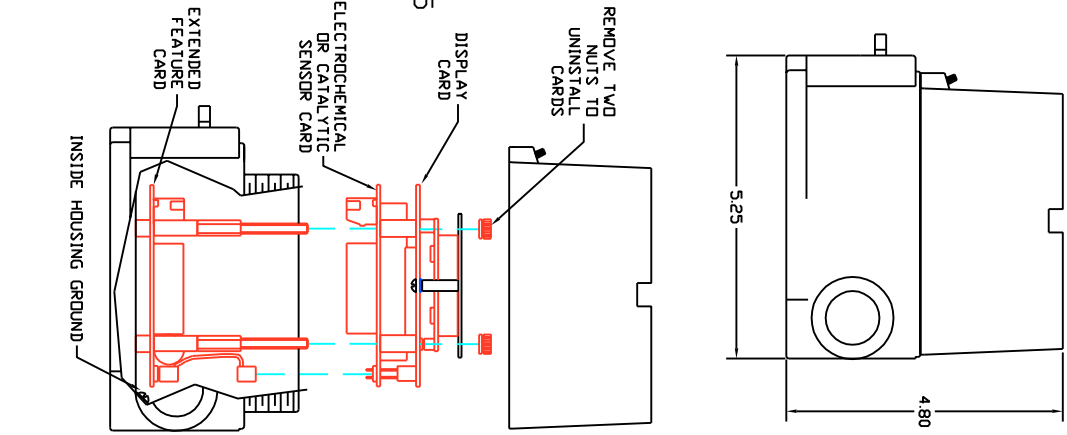
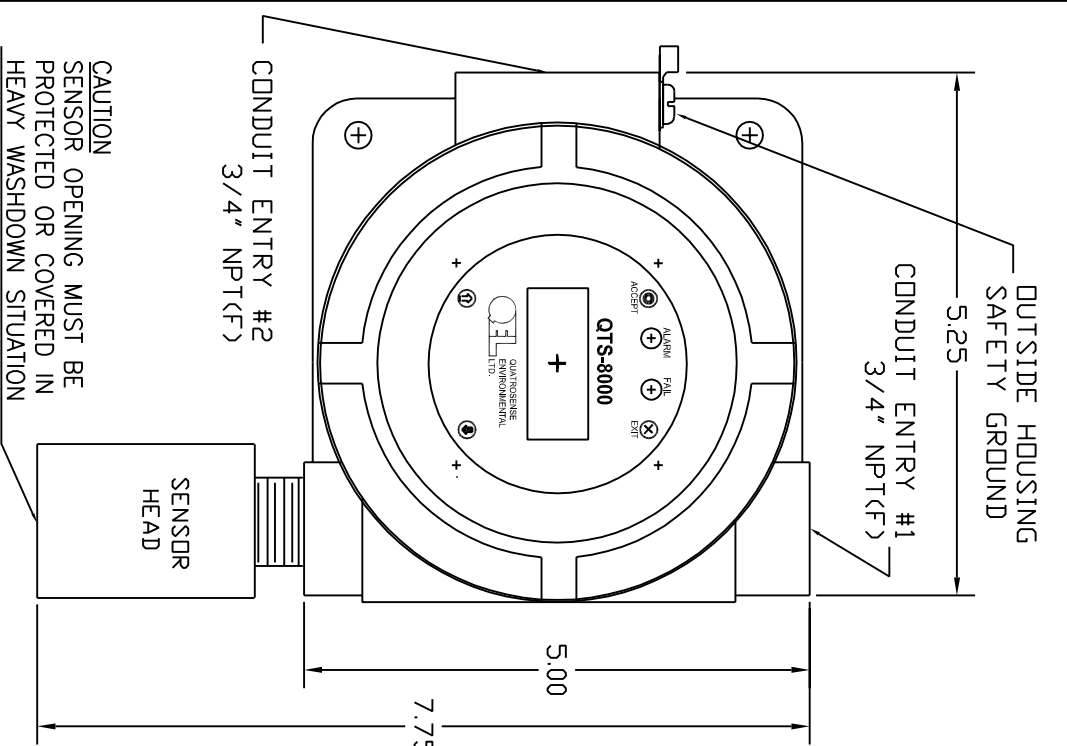

REV		DESCRIPTION		DATE		BY	
A	---	FIRST RELEASE	00-03-06	YD	BC	ARVD	BC
B	345	UPDATE TO RED LINE	00-05-03	YD	BC	BC	BC
C	403	ADD CAUTION NOTE	00-10-27	YD	SM	BC	BC
D	556	H2 = HIGH	03-06-19	YD	BC	BC	BC
E	579	UPDATE	03-08-11	YD	BC	BC	BC
F	647	03 SPAN -> 3PPM	2004/07	XY	XY	XY	XY
G	695	UPDATE TEMP SPEC	08-11-19	CLG	XY	XY	XY

TABLE FOR ELECTROCHEMICAL GAS

Gas	Model Code	Range PPM	Mounting	Operating Temperature MIN. C (°F) MAX. C (°F)
Hydrogen Sulphide	H2S 81110X	0-25 PPM	LDW	-40 (-40) +50 (122)
Hydrogen Cyanide	HCN 81115X	0-20 PPM	MID	-20 (-4)
Chlorine	Cl2 81120X	0-3 PPM	LDW	-20 (-4)
Chlorine Dioxide	ClO2 81123X	0-1 PPM	LDW	-20 (-4)
Hydrogen Chloride	HCL 81125X	0-10 PPM	MID	-20 (-4)
Oxygen	O2 81130X	0%-25%	MID	-20 (-4)
Sulphur Dioxide	SO2 81140X	0-6 PPM	LDW	-20 (-4)
Nitrogen Dioxide	NO2 81150X	0-6 PPM	LDW	-20 (-4)
Carbon Monoxide	CO 81160X	0-250 PPM	MID	-20 (-4)
Nitric Oxide	NO 81190X	0-100 PPM	MID	-20 (-4)
Hydrogen	H2 81211X	0-2000 PPM	HIGH	-20 (-4)
Ammonia	NH3 81220X	0-50 PPM	HIGH	-25 (-13) +50 (86)
Ozone	O3 81240X	0-3 PPM	MID	-20 (-4)

TABLE FOR CATALYTIC GAS

Gas	Model Code	Range (%LEL)	Mounting	Operating Temperature MIN. C (°F) MAX. C (°F)
Methane	CH4 81170X	0-100%	HIGH	-40 (-40) +50 (122)
Acetylene	C2H2 81171X	0-100%	HIGH	-40 (-40) +50 (122)
Ethane	C2H6 81172X	0-100%	MID	-40 (-40) +50 (122)
Propane	C3H8 81173X	0-100%	LDW	-40 (-40) +50 (122)
n-Butane	C4H10 81174X	0-100%	LDW	-40 (-40) +50 (122)
n-Pentane	C5H12 81175X	0-100%	LDW	-40 (-40) +50 (122)
n-Octane	C8H18 81176X	0-100%	LDW	-40 (-40) +50 (122)
Hydrogen	H2 81177X	0-100%	HIGH	-40 (-40) +50 (122)
Gasoline	81178X	0-100%	LDW	-40 (-40) +50 (122)
Others	81179X	0-100%	ADVISE	-40 (-40) +50 (122)

* Note:
 HIGH = 9 to 18" (0.23 to 0.46m) below ceiling.
 MID = 4 to 6 ft. (1.2 to 1.8m) above floor.
 LOW = 9 to 18" (0.23 to 0.46m) above floor.

EXTENDED FEATURE OPTION
 1. RS-485 PORT
 2. RELAYS (2)
 3. 24VAC/DC POWER

QUATROSENSE ENVIRONMENTAL LTD
 RICHMOND, ONTARIO, CANADA

OTIS-8000
 TRANSMITTER/SENSOR
 EXPLOSION PROOF INSTALLATION
 EXTENDED FEATURE OPTION

DRN. Y. DURE	00-03-06	SIZE	B
CHK. G.L.	00-03-20	TYPE	1
ISSON Y. DURE	00-03-06	DWG. NO.	82050-004-000
APPV.D		REV	5
INDUSTRIAL		FILENAME	SHEET 1 OF 5

CAUTION
 SENSOR OPENING MUST BE
 PROTECTED OR COVERED IN
 HEAVY WASHDOWN SITUATION

NOTE:
 1). Conduit entry #1 is for power and signal cable , remote acknowledge cable.
 Conduit entry #2 is for RS-485 and relay contact cables.

THIS DRAWING CONTAINS INFORMATION WHICH IS THE PROPRIETARY PROPERTY OF QUATROSENSE ENVIRONMENTAL LTD. THIS DRAWING IS RECEIVED IN CONFIDENCE AND ITS CONTENTS MAY NOT BE DISCLOSED WITHOUT THE PRIOR WRITTEN CONSENT OF QUATROSENSE ENVIRONMENTAL LTD.

1				
REV	ECO	DESCRIPTION	DATE	DRN / CHK / AP/VD
		SEE SHEET 1		

SPECIFICATIONS

INPUT POWER

24VDC nominal, range: 18 to 30VDC
 24VAC nominal, range: 15 to 24VAC

FUSE

1.0 Amp socketed pico fuse.

SENSORS

Electrochemical or Catalytic sensor.

SIGNALS

4-20 mA current signal, Max. load without HART multidrop connection:
 700 Ohms at 24V; 500 Ohms at 20V (optional: 0-10 VDC voltage signal, 1K Ohms output impedance, 5000 Ohms Min. load resistor).

ENCLOSURE

Explosion proof, CL I, Div. 1, Group B, C, D.

CALIBRATION

Initial internal adjustments/setting depending on sensor and range, Non-Intrusive calibration with magnetic tool, the cover need not be removed.
 Calibration recommendation: 90 days Max.

HUMIDITY

Sensor: 15 to 90% RH, non-condensing.
 Transmitter: 0 to 99% non-condensing.

PRESSURE

Atmospheric ±10%

KEYPAD

4 Mognetic sensors

LED INDICATOR

3 LED indicators for warning, alarm and fail status.

WIRES

AWG 14 - 24 (Ø0.54 - Ø1.6mm)
 RS-485 communication: 120 ohm, balanced, twisted pair (e.g. Belden 9841 or equivalent)

PAINTING

For combustible gas transmitter when painting in the area, turn off the transmitter and seal sensor opening with masking tape.

For toxic gas transmitter seal sensor opening with masking tape only

DISPLAY

2 x 8 Alphanumeric LCD with backlight.

RELAY

2 SPDT relays, 115 VAC, 30 VDC, 1 Amp

REMOTE RESET/ACKNOWLEDGE

For resetting latched relay and LED indicator.

Termination supplied for receipt of remote signal (24 VDC/VAC)

DATA COMMUNICATION

HART protocol (Pending)

MODBUS protocol

OPTO22

***NOTE:**

- 1). AC input power, Relays and RS-485 can only be available with extended feature option.
- 2). Wiring is needed only if the option is chosen.
- 3). 4-20 mA and 0-10 V signals cannot be used at the same time.

- EXTENDED FEATURE OPTION**
1. RS-485 PORT
 2. RELAYS (2)
 3. 24VAC/DC POWER

DRN	Y. DUBE	00-03-06	QUATROSENSE ENVIRONMENTAL LTD
CHK			RICHMOND, ONTARIO, CANADA
DESIGN	Y. DUBE	00-03-06	
AP/VD			
QA			
APPLICATION			
INDUSTRIAL			
SIZE	B	TYPE	1D
DIMENSIONS ARE IN INCHES		DWG NO	82050-004-000
DIMENSIONS ARE IN MILLIMETERS AND SHOWN FOR REFERENCE ONLY		SCALE	--
		FILENAME	
		SHEET	2 OF 5

THIS DRAWING CONTAINS INFORMATION WHICH IS THE PROPRIETARY PROPERTY OF QUATROSENSE ENVIRONMENTAL LTD. THIS DRAWING IS RECEIVED IN CONFIDENCE AND ITS CONTENTS MAY NOT BE DISCLOSED WITHOUT THE PRIOR WRITTEN CONSENT OF QUATROSENSE ENVIRONMENTAL LTD.

POWER SUPPLY CONNECTION

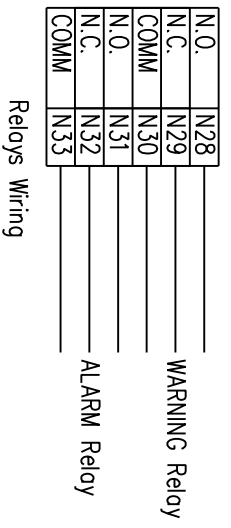
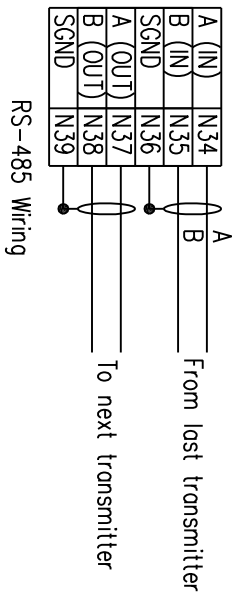
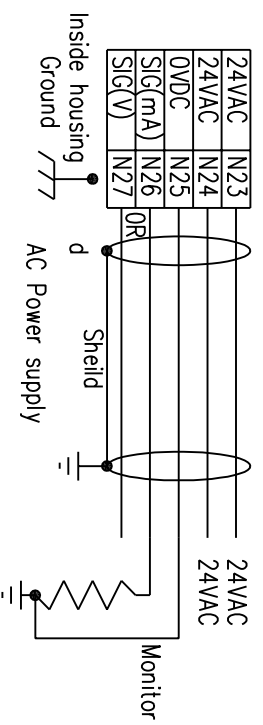
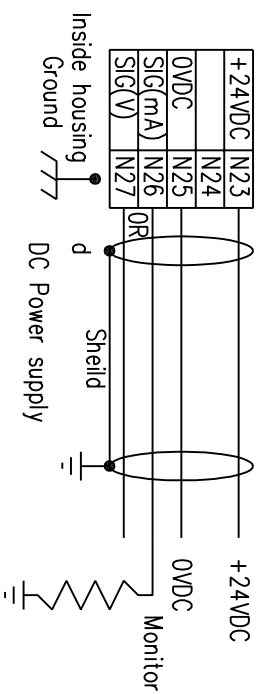

* For high EMI environment, the cable shield (at point d) connect to housing ground inside of the transmitter.

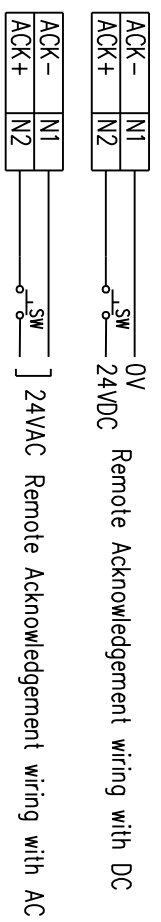

REMOTE ACKNOWLEDGEMENT FOR ELECTROCHEMICAL GAS TRANSMITTER

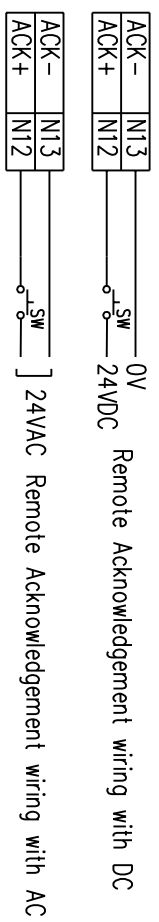

REMOTE ACKNOWLEDGEMENT FOR CATALYTIC GAS TRANSMITTER

- * SW - Remote Acknowledgement button
- * Remote Acknowledgement loop is isolated from power supply inside of the transmitter.

- EXTENDED FEATURE OPTION
1. RS-485 PORT
 2. RELAYS (2)
 3. 24VAC/DC POWER

REV		DESCRIPTION		DATE	DRN	CHK	APVD
			SEE SHEET 1				

DRN	Y. DUBE	00-03-06	QUATROSENSE ENVIRONMENTAL LTD
CHK			
DRN	Y. DUBE	00-03-06	OTS-8000
APVD			
QA			
APPLICATION			
INDUSTRIAL			
DIMENSIONS ARE IN INCHES			
DIMENSIONS IN PARENTHESES ARE IN MILLIMETERS AND SHOW FOR REFERENCE ONLY			
SIZE	B	TYPE	
ID		DRG NO	82050-004-000
SCALE		FILENAME	
SHEET	4	OF	5

THIS DRAWING CONTAINS INFORMATION WHICH IS THE PROPRIETARY PROPERTY OF QUATROSENSE ENVIRONMENTAL LTD. THIS DRAWING IS RECEIVED IN CONFIDENCE AND ITS CONTENTS MAY NOT BE DISCLOSED WITHOUT THE PRIOR WRITTEN CONSENT OF QUATROSENSE ENVIRONMENTAL LTD.

REVISONS		DATE	DRN	CHK	APV/D
REV	ECD	DESCRIPTION SEE SHEET 1			

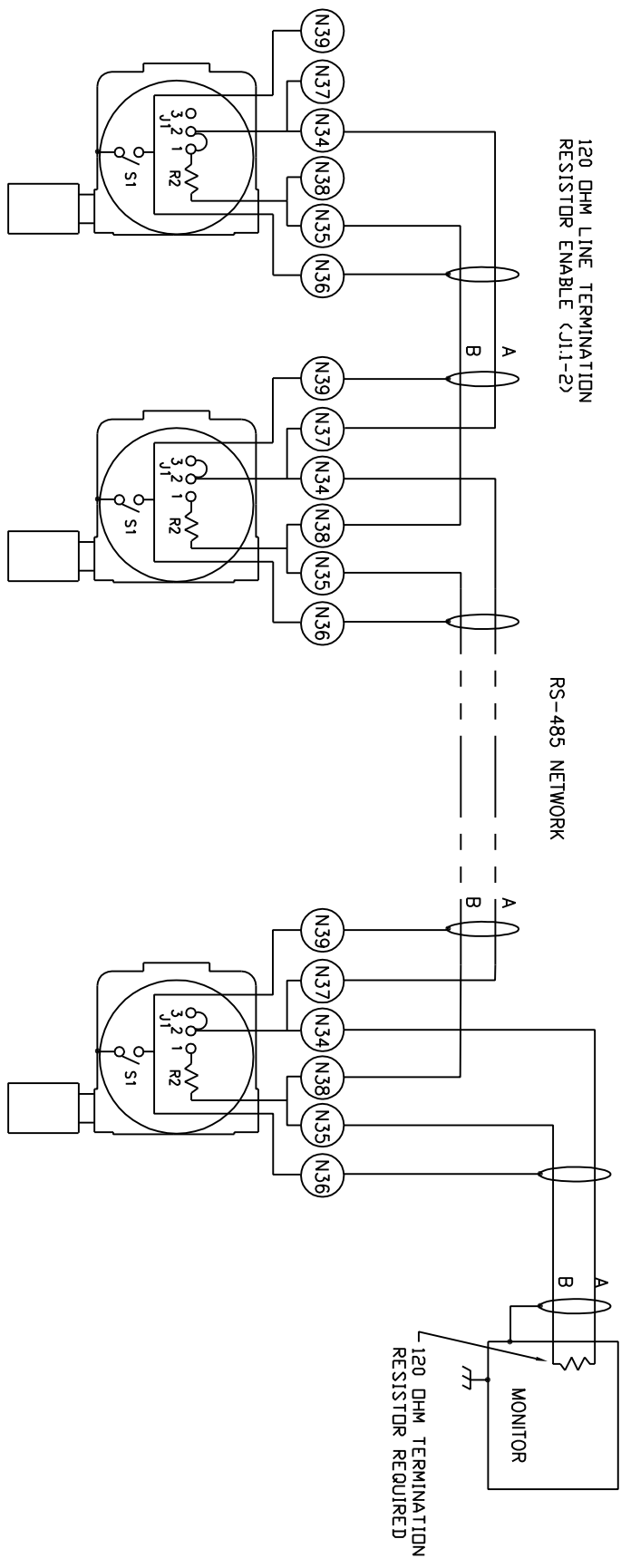

120 OHM LINE TERMINATION
RESISTOR ENABLE (J11-2)

RS-485 NETWORK

120 OHM TERMINATION
RESISTOR REQUIRED

- NOTE:
- 1- Ground the shield inside monitor (metal) case.
 - 2- If conduit grounds at monitor case then set dipswitch S1 (see I/O cord for physical position of S1) ON to ground shield to lost transmitter case.

- 3- If conduit is not a good ground, then some other method, depending upon installation is necessary, consult factory.
- 4- Grounding on one end protects against electrical fields only. Grounding inside the enclosures at both ends protects against electrical and magnetic fields.

Terminal resistor configuration in RS-485 network:
The terminal resistor (R2 on I/O cord) of the transmitter at two endpoints of the RS-485 network should be connected by connecting J1 jumper to 1-2 position (see I/O cord for physical position of R2 and J1.)

- EXTENDED FEATURE OPTION
1. RS-485 PORT
 2. RELAYS (2)
 3. 24VAC/DC POWER

DRN	Y. DUBE	00-03-06	QUATROSENSE ENVIRONMENTAL LTD		
CHK			RICHMOND, ONTARIO, CANADA		
DESIGN	Y. DUBE	00-03-06	OTS-8000		
APV/D			TRANSMITTER/SENSOR		
QA			EXPLOSION PROOF INSTALLATION		
APPLICATION			EXTENDED FEATURE OPTION		
INDUSTRIAL			DIMENSIONS ARE IN INCHES		
			DIMENSIONS IN PARENTHESES		
			ARE IN MILLIMETERS AND		
			SHOWN FOR REFERENCE ONLY		
SIZE	B	SCALE	REV	ID	82050-004-000
TYPE			G		
FILENAME	SHEET 5 OF 5				